Princeton Plasma Physics Laboratory

PPPL-

PPPL-



Prepared for the U.S. Department of Energy under Contract DE-AC02-09CH11466.

Princeton Plasma Physics Laboratory

Report Disclaimers

Full Legal Disclaimer

This report was prepared as an account of work sponsored by an agency of the United States Government. Neither the United States Government nor any agency thereof, nor any of their employees, nor any of their contractors, subcontractors or their employees, makes any warranty, express or implied, or assumes any legal liability or responsibility for the accuracy, completeness, or any third party's use or the results of such use of any information, apparatus, product, or process disclosed, or represents that its use would not infringe privately owned rights. Reference herein to any specific commercial product, process, or service by trade name, trademark, manufacturer, or otherwise, does not necessarily constitute or imply its endorsement, recommendation, or favoring by the United States Government or any agency thereof or its contractors or subcontractors. The views and opinions of authors expressed herein do not necessarily state or reflect those of the United States Government or any agency thereof.

Trademark Disclaimer

Reference herein to any specific commercial product, process, or service by trade name, trademark, manufacturer, or otherwise, does not necessarily constitute or imply its endorsement, recommendation, or favoring by the United States Government or any agency thereof or its contractors or subcontractors.

PPPL Report Availability

Princeton Plasma Physics Laboratory:

<http://www.pppl.gov/techreports.cfm>

Office of Scientific and Technical Information (OSTI):

<http://www.osti.gov/bridge>

Related Links:

[U.S. Department of Energy](#)

[Office of Scientific and Technical Information](#)

[Fusion Links](#)

Proliferation Risks of Magnetic Fusion Energy: Clandestine Production, Covert Production, and Breakout

A Glaser

Princeton University, Princeton, NJ

R J Goldston

Princeton Plasma Physics Laboratory and Princeton University, Princeton, NJ

ABSTRACT. Nuclear proliferation risks from magnetic fusion energy associated with access to weapon-usable materials can be divided into three main categories: 1) clandestine production of weapon-usable material in an undeclared facility, 2) covert production of such material in a declared facility, and 3) use of a declared facility in a breakout scenario, in which a state begins production of fissile material without concealing the effort. In this paper we address each of these categories of risks from fusion. For each case, we find that the proliferation risk from fusion systems can be much lower than the equivalent risk from fission systems, if the fusion system is designed to accommodate appropriate safeguards.

1. Introduction

In this paper we examine the proliferation risks that would be associated with the implementation of future magnetic fusion energy power systems, based on the deuterium-tritium (DT) fusion process. The DT fusion reaction produces a neutron, which can in principle be used to transmute fertile material to weapon-usable material. The overall nuclear cycle of interest is:



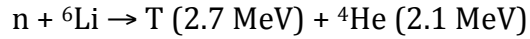

Lead or other materials such as beryllium that undergo (n, 2n) reactions are used between these steps to multiply neutrons so as to assure an adequate supply of T, in the face of inevitable parasitic neutron absorption. We do not treat here the special issues associated the classified nature of some aspects of inertial confinement fusion energy, which we have discussed elsewhere [1].

The weapons materials of interest for production by neutron irradiation are ${}^{239}\text{Pu}$ and ${}^{233}\text{U}$ via irradiation of uranium and thorium, respectively. Under the Nuclear Non-Proliferation Treaty (NPT), the IAEA has defined so-called “significant quantities” (SQ), which define *“the approximate amount of nuclear material for which the possibility of manufacturing a nuclear explosive device cannot be excluded,”* taking into account losses due to conversion and manufacturing processes. The significant quantity for both plutonium and ${}^{233}\text{U}$ is 8 kg [2]. Tritium is also produced and consumed in fusion reactors, but it is not controlled under the Non-Proliferation Treaty. In the absence of fissile materials, tritium cannot be used to produce a nuclear weapon. Some of the relevant issues associated with tritium have been discussed elsewhere [3].

There are three basic scenarios for nuclear proliferation based on fissile material production in the blanket of a DT fusion power system: first, clandestine production of weapon-usable material in an undeclared facility; second, covert production of such material in a declared facility; and third, use of a declared facility in a breakout scenario, in which a state begins production of fissile materials for weapons purposes without concealing the effort, i.e., after exiting from nonproliferation agreements. In this paper we address each of these categories of risks from fusion.

We do not address the legal aspects of bringing fusion energy systems under IAEA safeguards. Under the NPT, the IAEA applies safeguards to “all source or special fissionable material in all peaceful nuclear activities” in non-weapon states party to the treaty [4]. It should be noted, however, that the IAEA has not applied safeguards

to fusion reactors in the past and that, under routine operations, there would be no nuclear material present at a fusion plant.

In Section 2 we consider the risk of clandestine production, estimating the power consumption and detectability of a compact fusion system. In Sections 3 and 4, in preparation for analyses of the covert diversion and breakout scenarios, we provide computational estimates of the maximum rate of production of ^{239}Pu or ^{233}U from natural uranium or thorium mixed into a Pb-Li coolant for a fusion power system. In Section 5 we discuss the covert use of a fusion system for production of weapon-usable material, estimating the required amount of fertile material and its detectability. In Section 6 we consider the possibility of breakout, and estimate the time required to produce a significant quantity of weapon-usable material. In Sections 7 and 8, we conclude by contrasting the proliferation risks of fission and fusion systems, and make recommendations for further work.

2. Clandestine Production of Weapons Material

There is no credible risk that a gigawatt-scale fusion power system, or any other nuclear power system of this scale, could be built and operated in a clandestine fashion. However, since the current worldwide fusion research program operates devices that produce 14.1 MeV neutrons, one can ask if there is there a fusion equivalent to the small fission research reactors that produce plutonium in significant quantities and, if so, if such a device could be operated clandestinely.

Studies have been made of fission-fusion hybrid systems designed to breed fuel for fission reactors. It has been estimated that each 14.1 MeV fusion neutron could be used to produce up to 0.64 plutonium or ^{233}U atoms [5] consistent with a tritium-breeding ratio (TBR), i.e., tritons produced per neutron, of 1.06. This corresponds to 2.85 kg plutonium per MW-year of DT fusion power production, assuming that all of the neutrons are captured in the blanket. Current fusion experiments have produced about 10 MW of DT power, but at very low duty factor $\sim 10^{-3}$. They are also very visible. For example, the Tokamak Fusion Test Reactor (TFTR) at the Princeton

Plasma Physics Laboratory used up to 1000 MVA of pulsed magnet power. Operation required large energy storage and power conversion equipment. The site covers about 10 hectares, and the buildings cover 7000 m², not including the power substation, control room or cooling tower. The facility is easily discernable in publicly available satellite imagery.

Recently studies have been undertaken by Kuteev *et al* to determine the minimum size fusion device that can be used to prototype the production of fusion neutrons and their use for applications other than the direct production of energy, including potentially the production of fuel for fission reactors [6]. With optimistic extrapolations for both plasma physics and fusion technology, Kuteev *et al* find that a relatively compact research device, shown in Figure 1, drawing approximately 40 MW continuously from the grid, could produce 1.8 MW of continuous fusion power. With an optimistic duty factor of 85%, and assuming that 80% of all neutrons are captured in a uranium-bearing blanket, it could in principle produce 3.5 kg of plutonium or ²³³U per year, somewhat less than one-half SQ in either case.

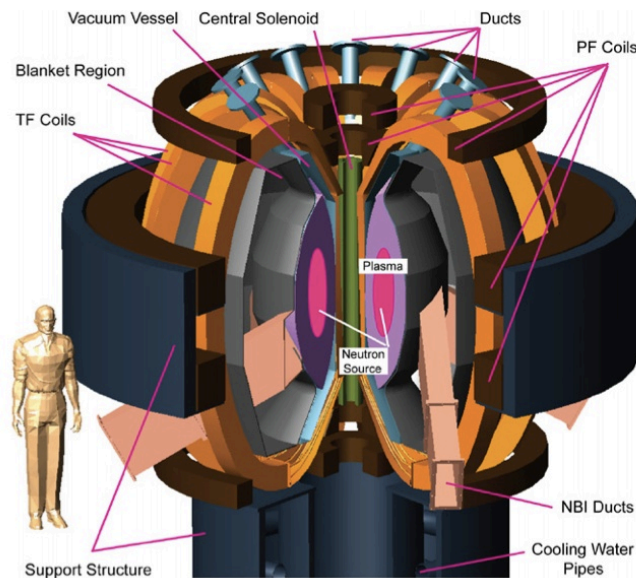

Figure 1. Compact fusion device for neutron production.

If such a device were able to be operated clandestinely, it would constitute a proliferation risk, but the requirements for ~40 megawatts of continuous power

input and cooling, and so a large electric supply line, large power conversion buildings to provide the DC power required to power the magnet coils, and a significant cooling facility as well as a very well shielded reactor building (whose size would be dominated not by the reactor but by the large neutral beam injection, NBI, plasma heating systems) would make such an installation quite visible. The remote handling capabilities needed for such a high-duty-factor DT facility would also be very visible. Based on experience with TFTR, trace levels of tritium lost from the facility would be detectable for a distance of tens of kilometers, in addition to the environmental signatures of fertile and fissile materials. Finally, the fertile material (uranium or thorium) needed to operate the plant would have to be covertly diverted from a safeguarded nuclear fuel cycle or produced in an undeclared facility. In our judgment, it is overall not credible that such a facility could be constructed and operated clandestinely.

A more speculative option might be to use an alternative fusion confinement device called a Gas Dynamic Trap, which confines plasma in an essentially linear (rather than toroidal) configuration. This has been proposed as a source of neutrons to test materials for use in the fusion environment [7,8]. Such a device, about 15 m long, is projected to require 60 MW of line power, while producing 2 MW of fusion power, rather similar parameters to the concept treated above.

3. Weapons Material Production via Fusion in a Lead-Lithium Blanket Module

To estimate the hypothetical weapons material production potential of a DT fusion power system using a lead-lithium breeder/coolant in covert diversion and overt breakout scenarios, we model a test-blanket module of a representative DEMO reactor based on the dual-coolant (liquid) lead-lithium blanket (DCLL) proposed by the United States. This blanket design has been detailed in the U.S. DCLL Design Description Document submitted to the ITER Test Blanket Working Group [9] and further refined since then. We use updated design information from Youssef *et al*,

summarized in Table 1, to simulate a module using the Monte Carlo N-Particle code MCNP [10].

Table 1. Blanket design and volume percent compositions used in MCNP calculations [10, 11]. Some lithium-lead (LL) is present in zones behind and between the breeding zones in the model, from LL flow pipes. PFC denotes the plasma-facing component; FW denotes the front wall. The back reflector has been added to simulate a more realistic power system environment.

#	Component	Outboard Module		Inboard Module		FS [vol%]	LL [vol%]	SiC [vol%]	He [vol%]
		Depth	Total	Depth	Total				
1.	PFC Layer	0.2 cm	0.2 cm	0.2 cm	0.2 cm	(100% Beryllium)			
2.	FW Front	0.4 cm	0.6 cm	0.4 cm	0.6 cm	100.0	--	--	--
3.	FW Cooling	2.0 cm	2.6 cm	2.0 cm	2.6 cm	17.0	--	--	83.0
4.	FW Back	0.4 cm	3.0 cm	0.4 cm	3.0 cm	100.0	--	--	--
5.	Breeding Ch. 1	22.5 cm	25.5 cm	22.5 cm	25.5 cm	1.9	80.8	7.6	9.7
6.	Divider 1	3.2 cm	28.7 cm	3.2 cm	28.7 cm	51.2	--	--	48.8
7.	Breeding Ch. 2	21.0 cm	49.7 cm	21.0 cm	49.7 cm	1.9	80.5	7.9	9.7
8.	Divider 2	3.2 cm	52.9 cm	(not present)		51.2	--	--	48.8
9.	Breeding Ch. 3	21.0 cm	73.9 cm			1.9	80.5	7.9	9.7
10.	Inner Manifold	8.0 cm	81.9 cm	8.0 cm	57.7 cm	45.3	--	--	54.7
11.	Back Plate	1.5 cm	83.4 cm	1.5 cm	59.2 cm	100.0	--	--	--
12.	Steel Shield	20.0 cm	103.4 cm	30.0 cm	89.2 cm	80.0	--	--	20.0
13.	Outer Manifold	40.0 cm	143.4 cm	25.0 cm	114.2 cm	43.0	25.0	3.0	29.0
14.	Vacuum Vessel	35.0 cm	178.4 cm	35.0 cm	149.2 cm	(70% FS; 30% H ₂ O)			
15.	TF Magnets	47.0 cm	225.4 cm	50.0 cm	199.2 cm	(50% FS; 30% Cu; 20% liquid He)			

We have built one-dimensional (radial) MCNP models for the inboard and outboard blankets, which accommodate two and three breeding channels, and therefore have different total depths, but are otherwise similar. The main materials used or present in the blanket are ferritic steel, lithium-lead, silicon-carbide, and helium. In our simulations, each radial zone is homogenized according to the respective volume fractions. For each case, we run MCNP separately for both blanket types, using the previously established result that 22% and 78% of the neutrons go to the inboard

and the outboard modules, respectively [10]. The blanket design examined here uses a lead-lithium eutectic (Pb-17Li) with 90% ^6Li enrichment.

Tritium breeding blankets are characterized by their local tritium breeding ratio (TBR), i.e., the number of tritium atoms produced in the blanket per incident 14.1 MeV neutron. The TBR for this design has been determined with MCNP calculations. The blanket is characterized by a TBR of 1.44 for the outboard module and a TBR of 1.31 for the inboard module, which results in an average value of 1.41. For a divertor coverage of 12%, this yields an overall tritium breeding ratio of 1.24 for the specified blanket design, which is in very good agreement with published calculations [10]. For the simulations below, we assume that 80% of the total surface can be covered with blanket modules resulting in a global TBR of 1.125. This is in line with what is estimated to be required to maintain a fusion reactor in steady-state operation, given additional parasitic absorption associated with auxiliary heating, diagnostic and control systems and inevitable inefficiencies and losses, and as well as the need to provide 1–2% margin to provide the tritium inventory for the startup of future fusion reactors [12].

Our MCNP calculations also show that about 16.5 MeV are deposited in the blanket system per incident 14.1-MeV neutron. For the estimates below, we assume that the reference plant generates 2500 MW of thermal power in the blanket, which corresponds to a plasma power of 2660 MW (including alpha particles) and an incident neutron rate of $9.42 \cdot 10^{20}$ n/s. This rate is used in the following to determine effective transmutation rates and total fissile material production in the system.

For a complete analysis, we also need an estimate of the total amount of lead-lithium in the system because, at any given time, only a fraction of this material is exposed to the neutron flux in the blanket. Here, we assume a total system inventory of liquid lead-lithium of 10,000 metric tons, which is generally considered a plausible value [13], and corresponds to a volume of 1.06×10^9 cubic centimeters. This reference value will be needed to confirm that the burnup of the nuclear material, i.e., the

fraction of ^{238}U or ^{232}Th converted to ^{239}Pu or ^{233}U , remains low. This will be true for all scenarios considered below. Production rates are then essentially constant and weapon-grade material of high isotopic purity is produced. A lead-lithium inventory of 10,000 tons also suggests that the amount of fertile material injected would have to be in the range of 500 tons in a practical breakout scenario maximizing fissile material production.

4. Simulation Results

Using the MCNP model of the blanket module as an approximation of a general, commercial lead-lithium cooled tritium-breeding module, we consider the following scenario. Uranium or thorium in a suitable form is brought to the site of a fusion power plant. An injection system is used to introduce the fertile material in the coolant. One approach would be to dissolve the fertile material in the lead-lithium eutectic, which is however limited by the low solubility of uranium and thorium [14]. An alternative strategy is considered here: it would begin with the injection of micro-fuel particles to avoid the problem of dissolving fertile material in liquid lead-lithium and later removing the small quantities of fissile material produced. These particles could be similar to so-called Tristructural-isotropic (TRISO) particles, which have been developed since the 1960s for fission-power systems and are considered again today for future nuclear power systems [15]. They are typically about one millimeter or less in diameter, contain a kernel with uranium or thorium, and are coated with various layers of graphite [16]. As the fissile material is bred in the blanket modules, a dedicated filtration system would perform removal of the foreign particles from the liquid lithium-lead. The fissile material could then be extracted from the recovered particles in a chemical separation step. TRISO particles have never been reprocessed on a commercial scale but various options, including a basic grind-and-leach process, have been demonstrated in the early 1960s [17].

For the production scenarios modeled below, we assume that simplified TRISO particles are used. To maximize the volume of the nuclear material in the particles,

these could have a uranium or thorium kernel with a single silicon-carbide coating. These less-common bistructural-isotropic (BISO) designs have been previously considered, especially for low-burnup fuels, such as ours. Our calculations are based on a fully homogenized blanket system but, for reference purposes and to calculate appropriate volume fractions, we assume a particle size of 1 millimeter containing an 800-micron kernel coated with a 100-micron silicon-carbide layer. The average density of these particles would be about 7 g/cc compared to 9.4 g/cc of liquid lead-lithium, which potentially raises buoyancy issues that may have to be avoided in a practical design.

There are two fundamental constraints that potentially limit the loading of fertile material: loss of tritium production and increased heat load in the blanket. Figures 2 and 3 and Table 1 summarize the main results of the MCNP simulations for the reference blanket system. For this analysis, the introduction of up to 400 TRISO-type particles per cubic centimeter in the liquid lead-lithium has been considered and modeled. The particles would occupy up to 16% of the available volume; as we will see below, however, the most credible breeding scenarios correspond to a lower particle loading.

Uranium. Loss of tritium production in uranium is weak due to the production of extra neutrons from fast-fission events in uranium (mostly in ^{238}U , Figure 2). For the same reason, however, additional heat deposition in the blanket is significant. As shown in Figure 3, 100 TRISO-type particles per cubic centimeter increase heat load from 16.5 MeV to more than 20 MeV per incident neutron (+20%), and 200 particles/cm³ increase heat load to 24 MeV/n (+45%). We assume that the power level of the plasma would have to be reduced by a corresponding margin to re-establish the reference heat load. It is not clear, however, that a fusion power plant designed for a specific fusion power operating point could operate with a large reduction in fusion power, compensated by fission power production. This would give rise to changes in the distribution of nuclear heating in the blanket, and associated temperature differences between components. Here we assume that the plasma power can be reduced by no more than 45–50%, effectively limiting the

TRISO loading to 200 particles per cm³. With these assumptions and with the effective transmutation rate (²³⁸U captures per incident neutron) determined in the simulations, effective fissile material production in the blanket can be calculated (Table 2). Overall, in the case of uranium, a maximum of about 20 kg of plutonium can be produced per week. This production rate is limited by heat load considerations.

Thorium. Compared to uranium, additional heat production in the blanket is much lower when thorium is used as the fertile material (Figure 3). The maximum concentration of 400 TRISO-type particles per cubic centimeter considered here only results in a 15%-increase. As shown in Figure 2, the effect of neutron absorptions in thorium on the tritium-breeding ratio, however, is much more pronounced. The drop of this ratio (rather than the heat load) would determine the long-term sustainability of fissile-material production, and it is unlikely that more than 100–150 TRISO-type particles could be injected per cubic centimeter without consuming more tritium than is produced in the plant if inevitable losses are taken into account. In this case, about 20 kg of ²³³U could be produced per week.

In Sections 5 and 6 below, we use these main results to examine covert production and breakout scenarios.

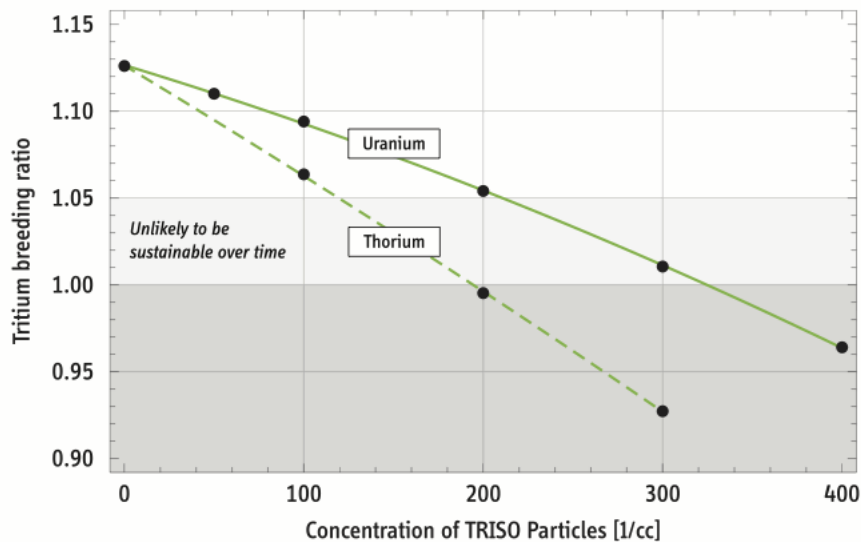

Figure 2. Tritium breeding ratio (TBR) blanket system. The concentration of the fertile material may be constrained by decrease in TBR or by additional heat load in the blanket, which would have to be counterbalanced by corresponding power reduction in the fusion plasma. A loss of 5–10% in TBR (i.e., from 1.125 to 1.070 and lower) is not likely to be sustainable in steady state.

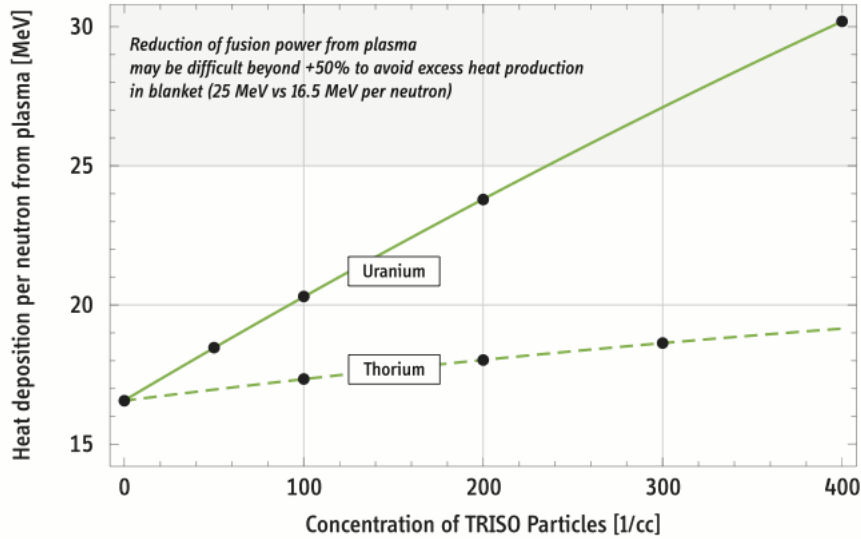

Figure 3. Total heat deposition in the blanket system per fusion neutron from plasma. For the reference system, each 14.1-MeV neutron generates about 16.5 MeV of heat in the blanket. Once TRISO particles are injected, heat generation in the blanket increases. We assume that the power level of the plasma would have to be reduced by a respective fraction to maintain a constant heat deposition in the blanket, and the maximum such adjustment would be about 50%.

Table 2. Main results of the Monte Carlo simulations. The plasma of the reference plant produces 2660 MW of fusion energy, equivalent to $9.42 \cdot 10^{20}$ neutrons per second (14.1 MeV neutrons, 80% of energy release in plasma, or about 2130 MW thermal). The transmutation rates correspond to neutron captures in ^{238}U or ^{232}Th per incident neutron. Maximum fissile material production specifies annual production rates of ^{239}Pu and ^{233}U in the fusion system for the reference blanket power level, i.e., with decreasing plasma power level as TRISO particle density increases.

URANIUM			
TRISO density	Initial Uranium Inventory	Plutonium Production Rate	Uranium Consumption
50 particles/cc	132.9 tons	6.8 kg/week	0.26% after 1 year

100 particles/cc	265.8 tons	12.5 kg/week	0.24% after 1 year
200 particles/cc	531.5 tons	21.9 kg/week	0.21% after 1 year

THORIUM			
TRISO density	Initial Thorium Inventory	Uranium-233 Production Rate	Thorium Consumption
100 particles/cc	265.2 tons	17.5 kg/week	0.34% after 1 year
200 particles/cc	530.4 tons	33.4 kg/week	0.32% after 1 year
300 particles/cc	795.6 tons	48.0 kg/week	0.31% after 1 year

5. Covert Weapons Material Production in a Declared Fusion Power Plant

The capability of detecting the presence of nuclear materials would be necessary if the IAEA were to safeguard declared fusion power system to ensure that no undeclared fissile material production is taking place. Ideally, measurements would be made minimally invasive while still ensuring appropriate detection probability. In the case of lead-lithium coolant, the most promising approach could be the detection of characteristic gamma emissions from either the fertile or the fissile material present in the lithium-lead matrix. To estimate the feasibility of this method, we consider a covert fissile-material production scenario, in which uranium or thorium is covertly diverted from a safeguarded fuel processing facility, or produced in an undeclared facility, and then added in a very small concentration to the coolant of the fusion reactor to produce one significant quantity (8 kg) of plutonium or ²³³U per year. Using the TRISO-particle scenario and the data from Table 2, this would correspond to a concentration in the range of one particle per cubic centimeter (1.1/cc and 0.9/cc for uranium and thorium, respectively) and a fertile inventory of 2.4–2.9 tons in the system.

To exclude such covert production in a declared and safeguarded fusion power plant, inspectors could look for undeclared injection and extraction systems or sample the liquid-lead and test for the presence of fertile materials. They could also employ radiation-detection strategies for both the uranium and the thorium

scenarios: in the case of uranium, they could seek direct detection of the ^{238}U based on its 1.001 MeV gamma line; in contrast, in the case of thorium, they could seek detection of ^{232}U , which is produced via (n, 2n) reactions in the ^{233}U bred in the thorium. We have used MCNP to generate spectrum-averaged neutron cross-sections and neutron flux profiles in the blanket module to calculate the ^{233}U and ^{232}U concentrations during irradiation. As expected, the concentration of ^{232}U remains extremely low, but the gamma line of one of its daughter products (2.614 MeV from ^{208}Tl decay) is strong. Table 4 summarizes the main results showing the effectiveness of the measurements. In both cases detection appears to be straightforward, although further work should be undertaken to evaluate impact of background radiation levels expected at a commercial gigawatt-scale fusion plant.

In the case of solid breeder blanket modules, it would be necessary for incoming components to be inspected for the presence of fertile material. This might be accomplished by passive means, looking for either γ 's or neutrons in coincidence, or by using the 14.1 MeV active neutron interrogation techniques that have been developed for detection of weapons materials in shipping containers. Sensitive environmental sampling techniques could therefore provide strong additional confidence in detecting covert use of a fusion power plant to produce weapons materials, since no fertile or fissile materials at all need be present at a fusion system.

Table 4. Detecting covert production of fissile material. We assume that a volume of 1000 cubic centimeters (containing about 9.4 kg of lead) is available for the measurement. To estimate detection rates, we place a detector with an active area of 100 cm² at 10 cm distance (about 8% detectable fraction) and assume a detector efficiency of 10%. For the thorium case, we calculate an effective capture cross section for ^{232}Th of about 0.40 barn and an (n, 2n) cross section for ^{233}U of 0.01 barn. Approximate uranium isotopics after one year of irradiation are about 0.002% ^{232}U , 99.6% ^{233}U , and 0.4% ^{234}U . Methodology adapted from [18].

	Uranium-238/Plutonium-239	Thorium-232/Uranium-233
Mass of fertile material in 1000 cc	2.75 g of uranium	2.25 g of thorium

Mass of material for measurement	2.73 g of ²³⁸ U	0.7 µg of ²³² U (about 50% of final concentration)
Gamma emission rate	220 per second (1.001 MeV)	185,000 per second (2.614 MeV)
Fraction of gammas escaping (self-shielding in sphere)	0.151 (for 1.001 MeV gammas in lead)	0.238 (for 2.614 MeV gammas in lead)
Detector signal	0.27 counts per second	350 counts per second
Time to detection	(minutes)	(seconds)

6. Breakout Scenario

The final case that we will consider is the “breakout scenario” in which a nation operating a fusion power plant subject to IAEA safeguards expels the inspectors and begins the production of weapons material as quickly as possible. This would require not only access to substantial quantities of nuclear fuel, but also either clandestine or covert production of specialized TRISO particles in advance of breakout, or manufacture of these particles after breakout.

A variant of this for fission systems is “abrupt diversion” where diversion is begun without announcement in the hope of gaining time before detection. Seals would need to be monitored, as currently for fission reactors, in order to minimize any delay of detection. The breakout scenario is currently a real concern in the case of fission, as illustrated by the withdrawal of the Democratic People’s Republic of Korea (DPRK) from the Non-Proliferation Treaty in 2003 and the subsequent reactivation of its weapons program. A critical aspect of the breakout scenario with fission is that significant weapons material has already been produced at the time of such a breakout. The case of a fusion power plant, however, is significantly different. No weapons materials would be available at the time of breakout if the facility were previously safeguarded and operated as declared. To put this distinction in perspective, we estimate the minimum period that would be required to produce one significant quantity of weapons material after breakout.

First, it would be necessary to introduce ^{238}U or ^{232}Th into the blanket system as outlined above. It is difficult to imagine that this could be accomplished in much less than one month, although engineering analyses of this should be undertaken. It is also not certain that the “gritty” fluid that would be produced by inserting hundreds of TRISO particles per cubic centimeter of lead-lithium coolant would flow in an unaltered manner through the pumps, filters, and complex geometries of a fusion blanket. This could be significantly affected as well by the high magnetic fields through which the coolant must flow. It is worth noting, however, that some fusion-fission hybrids, such as China’s fusion-driven hybrid system (FDS), have envisioned suspension of TRISO-type particles in lead-lithium slurries [15].

The analyses of Section 4 indicate that, once the device was operating, a fusion reactor could produce fissile material at a rate comparable to a fast-spectrum fission breeder reactor of similar power output [3]. In the uranium scenario, on the order of 500–1000 kg of plutonium could be produced per year. If time is short and the proliferator is expecting a determined international response, the fertile material could be removed and processed after 2–3 weeks to obtain sufficient fissile material for a small number of nuclear weapons (25–60 kg or 3–8 significant quantities). Plutonium for one significant quantity can be produced in the first week.

In some respects, the thorium scenario could be more attractive for breakout. As discussed in Section 4, the loading of fertile material in the blanket can be higher because blanket heating is less of a concern. A few significant quantities of ^{233}U could be produced in the first week after breakout and up to 1500 kg of ^{233}U could in principle be produced per year. This maximum production rate may not be sustainable for an extended period of time, however, if the plant is run below the tritium breakeven mode. A fusion power plant could have an inventory of tritium in storage in the range of 5–10 kg, for ultimate use in the startup of future fusion power plants. In a breakout scenario, a proliferator could choose to use up this inventory compensating for the reduction in tritium breeding ratio. For example, if the breeding ratio were reduced to 7.5% below the minimum required for tritium breakeven, ~30 g would be lost per day. Thus it would be possible to operate the

system for 1–2 years while consuming this inventory. For continuing operation, however, it is unlikely that a 7.5% reduction in TBR could be sustained.

In sum, the production rate for fissile material in a gigawatt-scale fusion reactor loaded to the maximum credible extent with TRISO particles would be large, and the time to obtain the first significant quantity of plutonium or ^{233}U would be dominated by preparing the system for production, e.g. by preparation of the nuclear fuel, if not previously performed, and injection of TRISO particles containing on the order of 500 tons of uranium or thorium. Commercial fusion system designs should minimize suitability for this scenario.

Alternatively, in a breakout scenario, it would also be possible to shut down the power plant prior to insertion of the fertile material, then to restart and operate the plant, and finally to extract the material during another shut-down period. In this case, it would also be possible to replace the blanket modules with alternate systems bearing fertile material in solid form, such as analyzed by Moir [4]. If the power system were equipped with test blanket access ports, as ITER will be (Figure 4), then use of these ports would likely constitute the quickest approach. ITER targets being able to replace test blanket modules in a period of one month. The additional time for restart of the facility would be at least one additional month [19]. ITER uses three mid-plane ports for test blanket modules, with a total area of 8 m². A commercial power plant might allocate similar space for testing new blanket designs; a practical upper limit for this might be 24 m². This would constitute an equivalent fusion power of about 100 MW, which would provide one significant quantity of weapons material in 10 days based on Moir's calculations. This area for test blanket modules should be limited in commercial fusion systems in order to extend the required period of time.

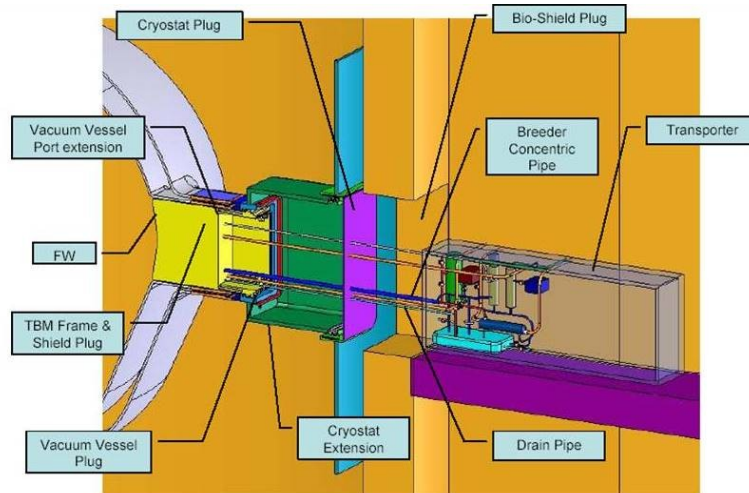

Figure 4. Test blanket module installed on ITER.

In sum, it appears that a time scale of 1–2 months would be required to produce one significant quantity of weapons material in a fusion power plant after the breakout scenarios we have analyzed here. This period is dominated by the time required to reconfigure and restart the facility. More analysis is required to refine this estimate, but it gives a sense of the time scale over which the international community would be able to react without concern that significant quantities of weapons material had already been produced. As with the fission breakout scenario, there are political and diplomatic options at this point, but unlike the fission case there is also the option to disable the plant and prevent the production of weapons material.

Fusion power plants require many supporting facilities that are non-nuclear in nature, but if deactivated would immediately prevent the power plant from operating. These include the massive power input and power conditioning equipment that provides electricity to the magnets, a very large cryoplant that provides liquid nitrogen and liquid helium to these magnets, and the cooling towers or water intakes and outflows that ultimately remove waste heat from the system. Such facilities can be seen in the layout of the ITER site, shown in Figure 5. These are distant from the fusion confinement system itself, and could be disabled without significant risk of nuclear contamination. The fact that this can be accomplished before

a significant quantity of weapon-usable material is produced represents a qualitative difference from the fission breakout scenario.

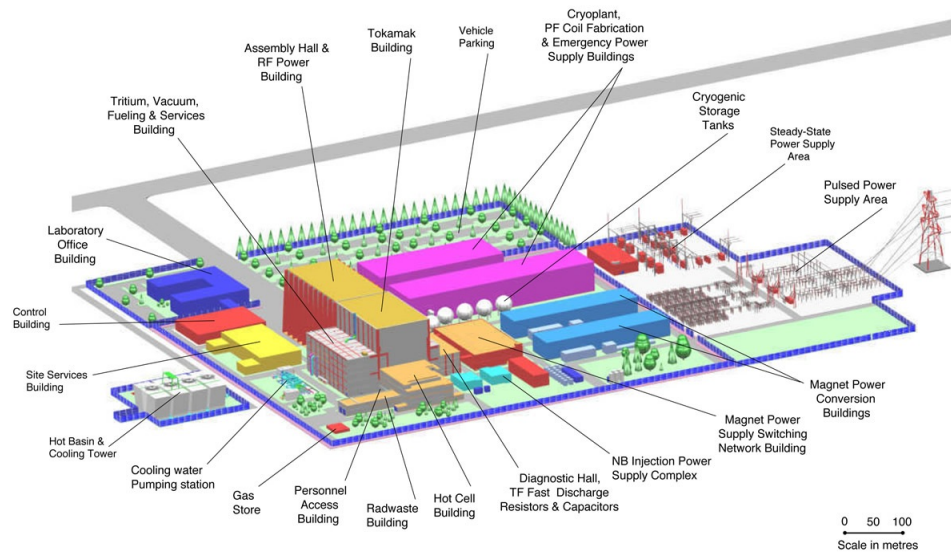

Figure 5. Generic site layout for the ITER facility, prepared before selection of the host country and construction site, which has resulted in modifications.

7. Comparison with Fission

The possibility of producing fissile materials for weapons purposes is a proliferation concern associated with several technologies and facilities used in the nuclear fission fuel cycle today. An undeclared centrifuge enrichment plant, for example, is extremely difficult to detect: A plant using first-generation technology sized to produce one significant quantity of highly enriched uranium per year draws less than 500 kW and occupies an area of perhaps 75 x 75 m². Covert diversion of plutonium from a declared reprocessing facility is another concern, since the measurement uncertainties in even the most modern facilities cannot be reduced to much less than 1%. In the case of a commercial-size reprocessing plant accepting spent nuclear fuel from 40 light-water reactors, this corresponds to an uncertainty of about 80 kg/yr of plutonium, or 10 SQ/yr. The availability of fissile materials, especially at a reprocessing plant under national control, makes the breakout

scenario for fission a credible risk. Furthermore, the yearly fueling for one GWe of fast reactor power is in the range of 2 tons of plutonium, or 250 SQ, an attractive option for the breakout scenario, since the IAEA estimates that such fuel can be converted for weapons use in 1 to 3 weeks [2]. For fission there is an additional category of long-term risk associated with plutonium in stored nuclear waste.

Thus fission systems present qualitatively higher risks than fusion systems in each of the three categories of access to weapons materials: clandestine production, covert diversion and breakout from safeguards.

As noted previously, researchers have also considered “hybridizing” fusion and fission. In principle the neutrons from fusion can be used for three purposes related to fission power: 1) multiplying the 20-MeV energy output from each fusion reaction by inducing fission reactions (200 MeV each) in a sub-critical fission blanket surrounding the fusion system; 2) breeding fuel for fission systems by transmuting ^{238}U or thorium to plutonium or ^{233}U ; and/or 3) using the energetic neutrons from fusion to “burn” plutonium and other transuranics or even long-lived fission products recovered from the reprocessed spent fuel of fission power plants. Combinations of these have also been examined. Relative to fission without reprocessing, some proposed approaches would reduce the need for uranium enrichment, and so would reduce the risk associated with clandestine centrifuge systems derived from national efforts. The risk of diversion of weapons material does not appear to be qualitatively different from fission systems with reprocessing, since substantial processing of nuclear fuels would be required in all cases, unless extremely high burnup can be achieved. The risk of breakout would be similar to fission with reprocessing. Some forms of fission-fusion hybrid would reduce the long-term risk associated with plutonium in stored waste. Overall, however, hybrid systems appear to inherit the main risks of fission with reprocessing, although more analysis should be done for specific proposals.

8. Conclusions

Ultimately, if designed to accommodate appropriate safeguards, fusion power plants would present low proliferation risk compared to fission. Our analysis suggests that clandestine production of weapons materials using fusion research facilities can be considered a highly implausible scenario. Detection of the covert use of a declared fusion power plant to produce even very small amounts of plutonium or ^{233}U appears to be straightforward if adequate IAEA safeguards approaches are implemented. The breakout scenario for fusion is qualitatively different from that for fission, because no weapons material is available at the time of breakout. We estimate that the world community would have 1–2 months to respond and prevent the production of weapons materials, without risk of dispersing radioactive materials.

We recommend future research to make these analyses more comprehensive and quantitative: more detailed assessment of the time required to add significant quantities of these materials to fusion blanket coolants, assessment of the flow of particles of fertile material and means to prevent this, assessment of the background radiation near coolant loops, more detailed analysis of the use of passive or active means to assay incoming materials at a fusion power plant, and more detailed engineering assessment of the time to replace test blanket modules and then to restart a fusion power plant. The proliferation risks of different fission-fusion hybrid schemes should also be carefully analyzed. Finally, and most importantly, we recommend that it would be appropriate now to examine the applicability of IAEA safeguards, including related legal and technical dimensions, to future fusion power systems.

Acknowledgments

The authors thank Mahmoud Youssef for details of his blanket design, Brad Merrill for discussions of Pb-Li handling, Yucan Wu and K M Feng for discussions of Chinese fission-fusion hybrid research. They thank Leonard Leibowitz and Mark Williamson of

Argonne National Laboratory for discussions of dissolution and reprocessing and David Campbell of the ITER International Organization for discussions of startup, and Neil Morley of UCLA for discussions of blanket technology. They thank George Perkovich of the Carnegie Endowment for International Peace for discussions of breakout scenarios and Olli Heinonen of the Harvard Kennedy School for feedback on safeguards issues. They thank Robert Fagerholm, Tom Killeen, Bruce Moran, Malcolm Nicholas, Tariq Rauf and Manfred Zendel of the IAEA for discussions of safeguards. This work supported in part by DOE Contract # DE-AC02-09CH11466.

REFERENCES

- [1] Goldston R J and Glaser A 2011, Inertial confinement fusion energy R&D and nuclear proliferation: The need for direct and transparent review, *Bulletin of the Atomic Scientists*, 67 (3), 59–66
- [2] IAEA 2002, *Safeguards Glossary, 2001 Edition*, International Atomic Energy Agency, Vienna
- [3] Goldston R J Climate Change 2011, Nuclear Power and Nuclear Proliferation: Magnitude Matters, *Science & Global Security*, 19 (2), 130–165
- [4] IAEA 1972, *The Structure and Content of Agreements Between the Agency and States Required in Connection with the Treaty on the Non-Proliferation of Nuclear Weapons*, INFCIRC/153, Vienna, Austria
- [5] Moir R W 1982, The Fusion Breeder, *Journal of Fusion Energy*, 2 (4/5), 351
- [6] Kuteev B V *et al* 2011 Steady State Operation of Tokamaks with Copper Coils, *Nuclear Fusion*, 51, 073013
- [7] Bagryansky P A *et al* 2004 *Fusion Engineering and Design*, 70, 13–33

- [8] Ivanov A A 2011 Fusion Neutron Research in Novosibirsk Including Experiments, *International Workshop on Fusion for Neutrons and sub-critical Nuclear Fission*, available at www.ifp.cnr.it/conference/FUNFI_presentations/index.html
- [9] Wong C P C *et al* 2005 Design Description Document for the U.S. Dual Coolant Pb-17Li (DCLL) Test Blanket Module, Revision 3
- [10] Youssef M Z, Morley N B and Dagher M 2009 Impact of the SiC FCI in the DCLL Blanket Module on the Nuclear Environment inside a Demo Reactor Configuration, *23rd Symposium on Fusion Engineering*, May 31–June 5, San Diego, CA
- [11] Youssef M Z 2010, University of California, Los Angeles, personal communication
- [12] El-Guebaly L A and Malang S 2009 Toward the ultimate goal of tritium self-sufficiency: Technical issues and requirements imposed on ARIES advanced power plants, *Fusion Engineering and Design*, 84, 2072–2083
- [13] El-Guebaly L A 2011 University of Wisconsin-Madison, personal communication
- [14] Ross A F 2008, “Nuclear Proliferation Risks of Fusion Energy”, Senior Thesis, Department of Physics, Princeton University
- [15] Wu *et al* 2006 Conceptual design of the fusion-driven subcritical system FDS-I, *Fusion Engineering and Design*, 81, 1305–1311
- [16] Sterbentz J W, Phillips B, Sant R L, Chang G S and Bayless P D 2004 Reactor Physics Parametric and Depletion Studies in Support of TRISO Particle Fuel Specification for the Next Generation Nuclear Plant, INEEL/EXT-04-02331, Idaho National Engineering and Environmental Laboratory
- [17] Ferris L M 1962 Chemical Processing of Coated Particle Fuels, ORNL-TM-193, Oak Ridge National Laboratory, www.ipfmlibrary.org/fer62.pdf.

[18] Fetter S *et al* 1990 Gamma-Ray Measurements of a Soviet Cruise-Missile Warhead, *Science*, 248, 18 May 1990, 828–834

[19] Campbell D J 2009 Fusion Science and Technology Department, ITER Organization, personal communication

The Princeton Plasma Physics Laboratory is operated
by Princeton University under contract
with the U.S. Department of Energy.

Information Services
Princeton Plasma Physics Laboratory
P.O. Box 451
Princeton, NJ 08543

Phone: 609-243-2245
Fax: 609-243-2751
e-mail: pppl_info@pppl.gov
Internet Address: <http://www.pppl.gov>