Princeton Plasma Physics Laboratory

PPPL-

PPPL-



Prepared for the U.S. Department of Energy under Contract DE-AC02-09CH11466.

Princeton Plasma Physics Laboratory

Report Disclaimers

Full Legal Disclaimer

This report was prepared as an account of work sponsored by an agency of the United States Government. Neither the United States Government nor any agency thereof, nor any of their employees, nor any of their contractors, subcontractors or their employees, makes any warranty, express or implied, or assumes any legal liability or responsibility for the accuracy, completeness, or any third party's use or the results of such use of any information, apparatus, product, or process disclosed, or represents that its use would not infringe privately owned rights. Reference herein to any specific commercial product, process, or service by trade name, trademark, manufacturer, or otherwise, does not necessarily constitute or imply its endorsement, recommendation, or favoring by the United States Government or any agency thereof or its contractors or subcontractors. The views and opinions of authors expressed herein do not necessarily state or reflect those of the United States Government or any agency thereof.

Trademark Disclaimer

Reference herein to any specific commercial product, process, or service by trade name, trademark, manufacturer, or otherwise, does not necessarily constitute or imply its endorsement, recommendation, or favoring by the United States Government or any agency thereof or its contractors or subcontractors.

PPPL Report Availability

Princeton Plasma Physics Laboratory:

<http://www.pppl.gov/techreports.cfm>

Office of Scientific and Technical Information (OSTI):

<http://www.osti.gov/bridge>

Related Links:

[U.S. Department of Energy](#)

[Office of Scientific and Technical Information](#)

[Fusion Links](#)

First real-time detection of surface dust in a tokamak^{a)}

C. H. Skinner^{1,b}, B Rais², A. L. Roquemore¹, H.W. Kugel¹, R. Marsala¹, T. Provost¹

¹ Princeton Plasma Physics Laboratory, Princeton, N. J., 08543, USA

² Université de Provence, Aix-Marseille, 13003, France

(Presented XXXXX; received XXXXX; accepted XXXXX; published online XXXXX)

(Dates appearing here are provided by the Editorial Office)

The first real-time detection of surface dust inside a tokamak was made using an electrostatic dust detector. A fine grid of interlocking circuit traces was installed in the NSTX vessel and biased to 50 V. Impinging dust particles created a temporary short circuit and the resulting current pulse was recorded by counting electronics. The techniques used to increase the detector sensitivity by a factor of x10,000 to match NSTX dust levels while suppressing electrical pickup are presented. The results were validated by comparison to lab measurements, by the null signal from a covered detector that was only sensitive to pickup, and by the dramatic increase in signal when Li particles were introduced for wall conditioning purposes.

I. INTRODUCTION

High levels of dust are expected in next step fusion devices because of the intense plasma-wall interactions and long pulse duration¹. The dust can be radioactive from tritium or activated tungsten, toxic, and/or chemically reactive with steam or air and the accumulation of dust will have operational and potential safety impacts in four areas. To limit the radiological source term in case of accidental release to the environment the quantity of dust in ITER will be maintained below 1,000 kg². An administrative limit of 670 kg is envisioned to take account of measurement uncertainties. Secondly, to limit the potential explosion hazard in case a coolant leak and simultaneous air ingress result in hydrogen generation from chemical reactions between dust on hot surfaces and steam/water, the quantity of dust on hot surfaces will be maintained below 6 kg of C and 6 kg of Be, or if C is absent, 11 kg of Be and 230 kg of W. Thirdly, dust transport to the core plasma will raise impurity concentrations, degrade fusion performance and may cause disruptions. Fourthly, dust may coat diagnostic mirrors necessary to monitor plasma operations and compromise their performance. The tolerable amount of dust for the last two issues is not known. Clearly dust detection and dust removal techniques will be vital to the operation of ITER and future fusion reactors.

The ITER strategy² includes indirect measurement of dust generation via measurements of the erosion of plasma facing components. Initially 100% of the erosion products will be conservatively assumed to be dust. Dust will be removed from the vessel by vacuum cleaning during the maintenance periods planned for divertor replacement and this is expected to be sufficient to maintain the global dust inventory below the 670 kg limit. Electrostatic traveling waves have been proposed to prevent the accumulation of dust on photovoltaic cells in space missions³ and initial results with a view applying this technology to dust removal in tokamaks are reported in refs.^{4,5}. Direct local measurements of dust are envisioned to provide information on

dust generation on a pulse-by-pulse basis with a measurement requirement of 20% relative and 50% absolute accuracy. However dust measurement techniques are still in their infancy, especially for dust on hot surfaces and to date no real-time measurements of surface dust in tokamaks have been reported.

A capacitive diaphragm pressure gauge that is adapted for use as a dust microbalance has been proposed for local dust measurements and a prototype with a sensitivity of 0.5 mg/cm² has been tested in the laboratory⁶. These devices rely on the long term measurement of nanometer-scale mechanical displacements and significant challenges remain to maintain thermal and mechanical stability in the face of ELMs and disruptions in the ITER divertor. An alternative technique relies on electrostatic effects and we report on the first real-time measurement of surface dust in an operating tokamak using this technique. The physics of dust in plasmas has been reviewed in ref. ⁷ and previous work on dust diagnostic techniques has been recently reviewed in refs. ^{8,9}.

II. LABORATORY DEVELOPMENT OF AN ELECTROSTATIC DUST DETECTOR

The device is designed to detect dust particles settling on a remote surface. In the present embodiment two closely interlocking combs of copper traces on a circuit board are biased at 30 - 50 V (Fig. 1). When a conductive dust particle settles on this surface a miniature spark is generated creating a transient short circuit and the resulting current pulse is detected electronically. At the same time the heat generated by the current vaporizes at least part of the particle causing it to rocket off the surface or vaporize. This restores the open circuit, resetting the detector for the next dust particle. Initial laboratory tests in air and vacuum using standard nuclear counting electronics (single channel analyzer) showed a correlation between the signal and amount of dust and, in the early work, a threshold sensitivity of ~50 µg/cm² in air at a trace spacing of 127 µm was measured^{10,11}. However this sensitivity is approximately 4 orders-of-magnitude above that needed to detect dust falling during one pulse in contemporary tokamaks so further development was needed.

An increase in sensitivity (expressed in counts / areal density (count/ng/cm²)), of more than an order of magnitude was

^{a)}Contributed paper published as part of the Proceedings of the 18th Topical Conference on High-Temperature Plasma Diagnostics, Wildwood, New Jersey, May, 2010.

^{b)}Author to whom correspondence should be addressed. Electronic mail: cskinner@pppl.gov

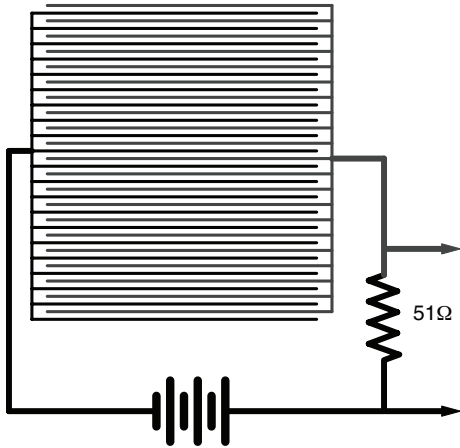

FIG. 1. Schematic of dust detector (not to scale) showing interlocking combs of traces. Dust impinging on the traces causes a short circuit and a voltage signal is generated across the 51 Ω resistor.

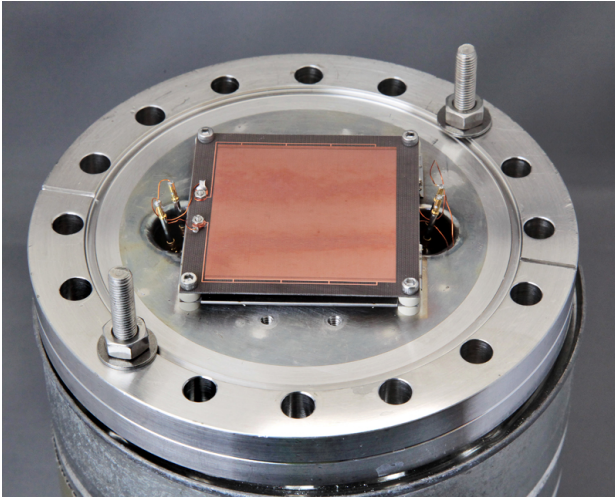

Figure 2. Dust detector before installation in NSTX.

obtained with ultrafine traces with 25 μm separation¹². The carbon test particles used in the initial experiments ranged from 1 – 500 μm in size with most of the particles being close to 1 μm . The sensitivity was measured with particles in different size ranges to determine if the detector response was predominately from the relatively few particles with size sufficient to bridge the gap between traces or from the many particles smaller than the gap size. It was found that the response was the highest for the finest particles. This is a favorable property for tokamak dust which is predominately of micron scale. The number density of incident particles (whatever their size) was the dominant factor in the response. Qualitative information on the size of the particles was also apparent as larger particles generated longer current pulses.

Typically open circuit conditions are rapidly restored indicating that the dust particles have been removed from the circuit board. The fate of the dust particles was tracked by measurements of mass gain/loss. Heating by the current pulse caused up to 90% of the particles to be ejected from the circuit board¹³. Further improvements in detector sensitivity were obtained by increasing the area of the detector from 12.7 x 12.3 mm to 50.8 x 50.8 mm¹⁴. A high sensitivity balance was used to

measure microgram levels of dust delivered to the detector and the response was quite linear down to the lowest mass indicating that single particles were sufficient to cause breakdown. To bridge the remaining gap in detector sensitivity compared to the dust levels in present tokamaks, the detection electronics were modified¹⁵. A low pass filter used for signal conditioning was removed, and the single channel analyzer voltage threshold was lowered. The sensitivity further increased by a factor-of-two when the bias voltage was decreased from 50 V to 25 V, possibly because multiple pulses were generated from the same particle as it was not promptly ejected from the circuit board. Altogether these changes in the electronics increased the sensitivity (count/ng/cm²) a further factor of x120 bringing it to the level required.

III. DUST DETECTION ON NSTX

The National Spherical Torus Experiment (NSTX) is a low aspect ratio tokamak aimed at establishing the physics basis for next-step devices such as a plasma facing component test facility and to support ITER¹⁶. The trajectories of dust particles in the plasma have been recorded by stereoscopic fast cameras and compared to modeling¹⁷. Dust samples were also taken with a vacuum pump and filter attachment from several locations in the NSTX vessel during a maintenance period and the average count median diameter of this dust was found to be 3.27 μm ¹⁸. Surface dust levels at the bottom of the vessel were measured by weighing the dust collected on a glass slide over 1249 discharges resulting in an average dust level of 5.6 ng/cm²/discharge¹³. Particles that had accumulated on a viewport at the bottom of the vessel after 520 discharges were also examined with a digital optical microscope¹¹. The particle density was 313,500 particles/cm², with a count median diameter 2.06 μm , similar to values found in other tokamaks. This direct viewing method gives a direct measure of the particle areal density and has the advantage that the dust is not disturbed by a dust collection technique.

A. Detector configuration

Two 50.8 mm electrostatic detectors were mounted on a 15 cm conflat flange (Fig. 2). To distinguish the dust signal from electrical pickup, two circuit boards were used in NSTX, one above the other. The lower board was covered with mica to prevent any dust from reaching it and was therefore only sensitive to electrical pickup. A stainless steel wire mesh with pore size 90 μm x 90 μm covered both detectors and prevented large debris and fibers from settling on the detector.

The detector was installed at a vertical port 60 cm below a 5 cm wide radial slot located between the outer divertor and inner passive plate at Bay C (Fig. 3). This was isolated from the vacuum vessel by a double gate valve (two gate valves were necessary as falling dust could interfere with the valve seal). The assembly was wrapped in heater tape and baked to a temperature of 65 $^{\circ}\text{C}$ for 36 hours to outgas volatile molecules from the components before the gate valves were opened to the NSTX vacuum. Triaxial cables 30 m long connected the detectors to the 50 V supply and detection electronics. Intershot helium glow discharges is sometimes performed on NSTX for wall conditioning purposes. To prevent any potential interactions the detector bias voltage was automatically disconnected during periods of glow.

The changes described in sect. II had increased the sensitivity by 4 orders-of-magnitude, however this caused some

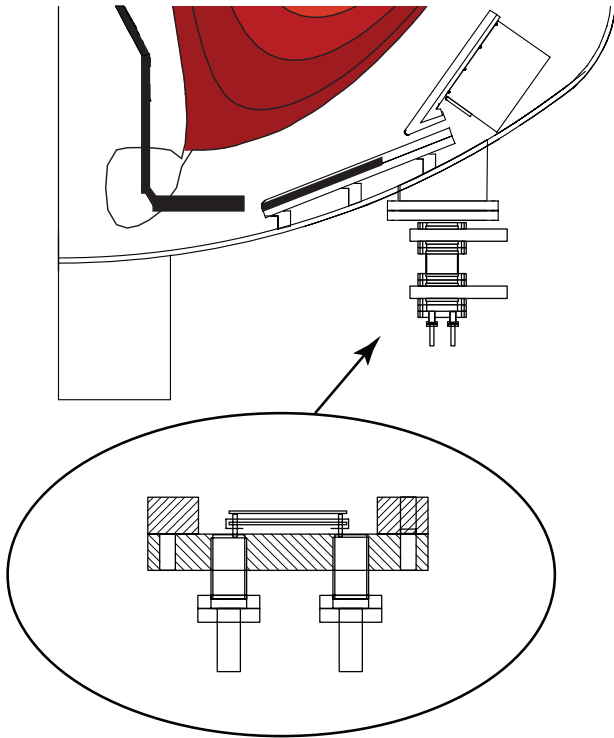

FIG. 3. Poloidal cross section of NSTX vessel with close up of dust detector.

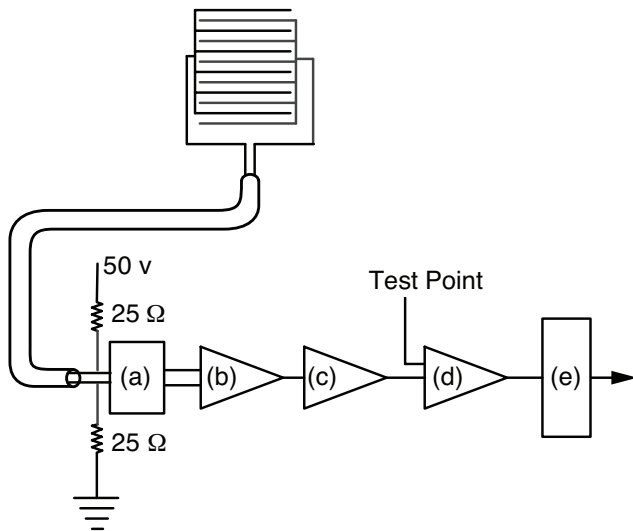

FIG. 4. Schematic of differential detection electronics. See text for explanation of components.

initial problems in the tokamak environment. With the bias set to 30 V for maximal sensitivity the dust particles were not always cleared from the detector and a permanent short could occur. In some cases this could be cleared by cycling the bias voltage on and off many times, but this was inconvenient. The voltage was increased back to 50 V which avoided this problem. A second issue was in confidently distinguishing dust signals from electrical pick-up in the tokamak electrical environment with

high power RF and switched power amplifiers (SPAs) in the vicinity.

B. Detector electronics

A differential detection electronics circuit was implemented to address this and is shown schematically in Fig. 4. The detector is biased to 50 V through 25 Ω resistors rated at 44 W - 4 times the maximum power that can be supplied in case of a complete short circuit. The balanced inputs from the detector are first attenuated by a factor 10 using a precision differential attenuator (a), and input to an Analog Devices (www.analog.com) 10 MHz instrumentation amplifier, AD8250ARMZ with a gain of unity (b). The amplifier is followed by a low pass filter that is switchable between 200 ns and 5.6 μ s (c) (set to 200 ns for this work) and a comparator (d) that compares the signal to an adjustable reference trip point. This is currently set to 4.58 V and corresponds to a resistance between the detector traces of less than 480 Ω . When the signal is lower than the trip point a 5 V output pulse is fed to a non-retriggerable one-shot that outputs a 1 microsecond pulse to a Bi Ra 911 latching scalar with a 256k memory module. Data from this is acquired at 1 kHz from a period of - 10 s to + 55 s with respect to the initiation of the plasma. Two identical and independent electronics channels were used for the two detectors.

C. Detector calibration

The laboratory dust source¹⁵ was taken to the NSTX test cell to characterize the time history of a known dust signal. A typical signal from dust released by a one-time event (knock) is shown in Fig. 5 (for this measurement an earlier, non-differential version of the detection electronics¹⁵ was used). The signal extends over 10 seconds or more as the particles interact with the circuit board. The detector was absolutely calibrated in the laboratory. Carbon particles were scraped from a spare NSTX ATJ graphite tile and the particle size measured by microscopic imaging and particle size analysis as described in ref. ¹². The count median diameter was determined to be 2.14 μ m, similar to the particles from NSTX. A few micrograms of carbon particles was dropped on the detector in air and vacuum and the response of the differential detection electronics was recorded. Data from a 50.8 mm detector covered with the 90 μ m pore mesh is shown in Fig. 6. The threshold sensitivity of the 50.8 mm detector to carbon particles in vacuum is 0.15 ng/cm²/count. This data includes some counts triggered by residual dust on the detector after the dust source was removed. The detector was cleaned with compressed gas in between each measurement. In NSTX the response may be somewhat influenced by residual dust and a gas puffing system is under development. The equipment was moved to an argon filled glove box to repeat the calibration with 40 μ m diameter lithium particles¹⁹. These particles are used for NSTX wall conditioning (see below) and the argon was necessary to minimize the oxidation of the lithium particles during handling. A 12 mm detector was used with the lithium particles and the sensitivity in vacuum without mesh cover was measured to be 14.5 ng/cm²/count. The lower sensitivity for the larger Li particles is consistent with the results of ref.¹². A detailed account of the calibration is given in ref.²⁰.

IV. FIRST RESULTS ON NSTX

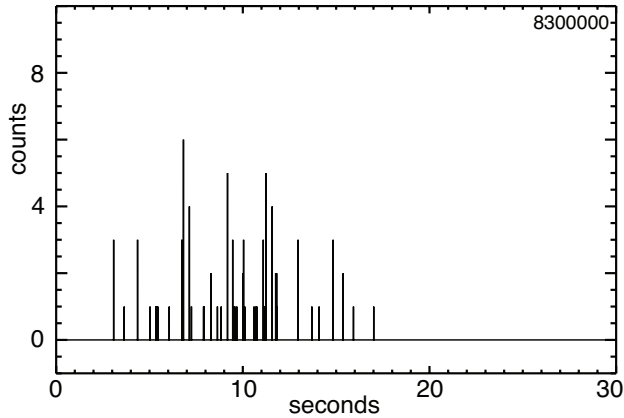

FIG 5. Signal generated by laboratory dust source incident on detector as recorded by the NSTX data acquisition system.

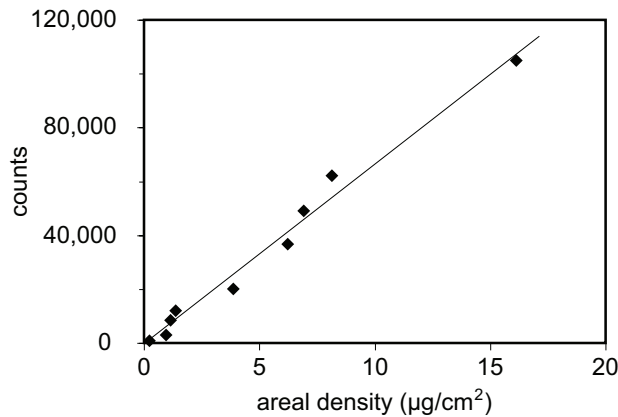

FIG 6. Response of 50.8 mm detector to carbon dust in vacuum, using a 50 V bias, differential counting electronics, and mesh cover. The line is a linear fit to the data

The first day of detector operation with NSTX discharges showed a signal up to 70 counts on the upper (open) detector (Ch.1) with zero (or in one case 2) counts on the mica covered detector (Ch.2). The time history of the Ch.1 signal (Fig. 7a) was similar to that obtained with the laboratory dust source. The lack of signal on Ch.2 (Fig. 7b) is strong evidence that the Ch.1 signals are due to dust. The history of the total number of counts vs. shot number for July and August 2009 is shown in Fig. 8. The signal (pickup) on the covered detector is zero (not plotable on the log plot), or a few counts in less than 10% of discharges. On two days the tokamak was electrically reconfigured for coaxial helicity injection (CHI) and up to 17 counts pickup was observed for a few CHI discharges.

The conspicuous two-order-of-magnitude increase in dust signal starting with shot number 135832 is correlated with the operation of a lithium aerosol at Bay C upper port (directly above the dust detector). This drops lithium particles¹⁹ into the plasma for wall conditioning purposes²¹. A second large increase in the dust signal is coincident with the second operation of the Li aerosol on shot 136150. The exact correlation of aerosol operation with the increase in dust signal is compelling evidence that the dust signals are due to particles impinging on the detector. The signal markedly decreases after the aerosol ceases operation, but does not return down to the original level indicating that a few % of the particles may remain on the detector (consistent with laboratory results¹³). Some lithium particles were visible on the detector after it was retrieved from

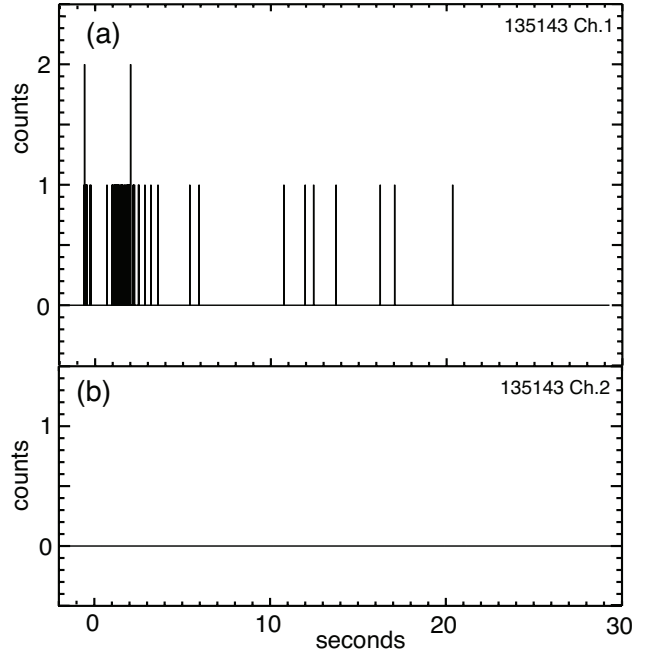

FIG 7. (a) Dust signal - there is a total of 64 counts from dust; (b) the simultaneous null signal from the covered detector.

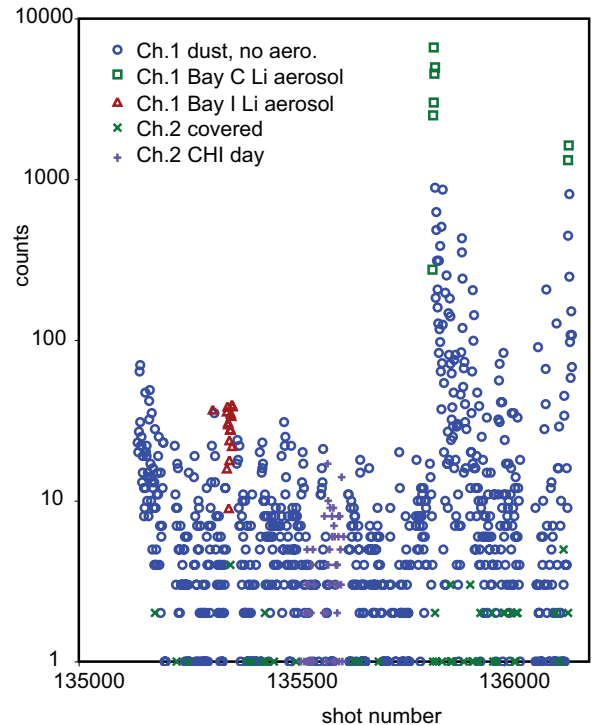

FIG 8. (a) Time history of channel 1 (open detector) and channel 2 (covered detector) signals vs. shot number over July and August 2009. The points where the Li aerosol was operated are distinguished in the legend. Note the two-order-of-magnitude increase in signal with the operation of the Bay C Li aerosol.

the vessel at the end of the campaign. In future work a helium gas puffing system such as described in ref.⁵ will be added to periodically clear residual particles remaining on the detector.

In summary, we report the first real-time detection of surface dust inside a tokamak. Details of the correlation of the dust signals with plasma events will be reported separately. We note that development work remains to make these detectors compatible with the harsh ITER in-vessel environment. The detector will need to be fabricated from radiation resistant materials and operate reliably for long periods without maintenance. A ruggedized detector is needed to detect tungsten dust. However the dust levels of concern in ITER are much higher than the levels in existing tokamaks. One kg of dust spread uniformly over the ITER horizontal cross section corresponds to 0.60 mg/cm² so a less sensitive detector with thicker, more rugged traces would be appropriate.

Acknowledgements

The authors would like to thank National Undergraduate Fellows: A. Bader, D. Boyle, A. Campos, C. Parker, R. Hensley, C. Voinier for previous work and C. Bunting, M. Cropper, and T. Holoman for technical assistance. We are indebted to D. Mansfield for assistance in handling the lithium particles. This work was funded by US DOE Grant No DE AC02-09CH11466.

- ¹ G. Federici, C.H. Skinner, J.N. Brooks, J.P. Coad, C. Grisolia, A.A. Haasz, A. Hassanein, V. Philipps, C.S. Pitcher, J. Roth, W.R. Wampler, and D.G. Whyte, *Nucl. Fus.*, **41**, 1967 (2001).
- ² S. Rosanvallon, C. Grisolia, P. Andrew, S. Ciattaglia, P. Delaporte, D. Douai, D. Garnier, E. Gauthier, W. Gulden S.H. Hong, S. Pitcher, L. Rodriguez, N. Taylor, A. Tesini, S. Vartanian, A. Vatry, and M. Wykes, *J. Nucl. Mater.*, **390-391** (2009) 57.
- ³ C.I. Calle, J.L. McFall, C.R. Buhler, S.J. Snyder, E.E. Arens, A. Chen, M.L. Ritz, J.S. Clements, C.R. Fortier, and S. Trigwell, *Proceedings of the ESA Annual Meeting on Electrostatics 2008* p.1.
- ⁴ C.H. Skinner A. Campos, H. Kugel, J. Leisure, A.L. Roquemore, and S. Wagner, *Proceedings of IAEA Fusion Energy Conference, October 13-18th 2008, Geneva, Switzerland, Paper IT/P6-26*.
- ⁵ A Campos and C.H. Skinner, *J. of Undergraduate Research* **IX** (2009) 30, available from: http://www.scied.science.doe.gov/scied/JUR_v9/default.htm
- ⁶ G. Counsell, A.P.C. de Vere, N.St.J. Braithwaite and S. Hillier, P. Bjorkman, *Rev. Sci. Instrum.*, **77** (2006) 093501.
- ⁷ S.I. Krasheninnikov A.Yu Pigarov, R.D. Smirnov, M. Rosenberg, Y. Tanaka, D.J. Benson, T.K. Soboleva, T.D. Rognlien, D.A. Mendis, B.D. Bray, D.L. Rudakov, J.H. Yu, W.P. West, A.L. Roquemore, C.H. Skinner, J.L. Terry, B. Lipschultz, A. Bader, R.S. Granetz, C.S. Pitcher, N. Ohno, S. Takamura, S. Masuzaki, N. Ashikawa, M. Shiratani, M. Tokitani, R. Kumazawa, N. Asakura, T. Nakano, A.M. Litnovsky, R. Maqueda and the LHD Experimental Group, *Plasma Phys. Control. Fus.* **50** (2008) 124054.
- ⁸ C.J. Lasnier, S.L. Allen, J.A. Boedo, M. Groth, N.H. Brooks, A. McLean, B. LaBombard, C.H. Skinner, D.L. Rudakov, W.P. West, and C.P.C. Wong, *Fus. Sci. and Technol.* **53** (2008) 640.
- ⁹ D.L. Rudakov J.H. Yu, J.A. Boedo, E.M. Hollmann, S.I. Krasheninnikov, R.A. Moyer, S.H. Muller, A.Yu. Pigarov, M.Rosenberg, R.D. Smirnov, W.P. West, R.L. Boivin, B.D. Bray, N.H. Brooks, A.W. Hyatt, C.P.C. Wong, A.L. Roquemore, C.H. Skinner, W.M. Solomon, S. Ratynskaia, M.E. Fenstermacher, M. Groth, C.J. Lasnier, A.G. McLean, and P. C. Stangeby, *Rev. Sci. Instrum.*, **79** (2008) 10F303.
- ¹⁰ A. Bader C.H. Skinner, A.L. Roquemore, and S. Langish, *Rev. Sci. Instrum.*, **75** (2004) 370.
- ¹¹ C.H. Skinner A.L. Roquemore, A. Bader, W.R. Wampler, *Rev. Sci. Instrum.*, **75** (2004) 4213.
- ¹² C. Voinier C.H. Skinner, A.L. Roquemore, *J. Nucl. Mater.*, **346** (2005) 266.
- ¹³ C.V. Parker, C.H. Skinner and A.L. Roquemore, *J. Nucl. Mater.*, **363-365** (2007) 1461.

- ¹⁴ C.H. Skinner, R. Hensley and A.L. Roquemore, *J. Nucl. Mater.*, **376** (2008) 29.
- ¹⁵ D.P. Boyle, C.H. Skinner, A.L. Roquemore, *J. Nucl. Mater.*, **390-391** (2009) 1086.
- ¹⁶ D.A. Gates et al., *Nucl. Fus.* **49** (2009) 104016.
- ¹⁷ A.L. Roquemore N. Nishino, C.H. Skinner, C. Bush, R. Kaita, R. Maqueda, W. Davis, A.Yu Pigarov, S.I. Krasheninnikov, *J. Nucl. Mater.*, **363-365** (2007) 222.
- ¹⁸ J.P. Sharpe P.W. Humrickhouse, C.H. Skinner, T. Tanabe, K. Masaki, N. Miya, A. Sagara, *J. Nucl. Mater.*, **337-339** (2000) 1000.
- ¹⁹ Stabilized Metallic Lithium Powder from FMC corporation (trade marked SLMP). Particle size is 44 micron average diameter with a 40 nm coating of Li₂CO₃.
- ²⁰ B. Rais, C.H. Skinner "Calibration of an electrostatic dust detector" PPPL report PPPL-4537 July 2010.
- ²¹ D.K. Mansfield A.L. Roquemore, H. Schneider, J. Timberlake, H. Kugel, M.G. Bell and the NSTX research team., *Proceedings of the 2nd NIFS-CRC International Symposium on Plasma-Surface Interactions NIFS, Toki, Gifu, Japan January 18-20, 2010, to be published in Fus. Eng. & Des.*

The Princeton Plasma Physics Laboratory is operated
by Princeton University under contract
with the U.S. Department of Energy.

Information Services
Princeton Plasma Physics Laboratory
P.O. Box 451
Princeton, NJ 08543

Phone: 609-243-2245
Fax: 609-243-2751
e-mail: pppl_info@pppl.gov
Internet Address: <http://www.pppl.gov>