

PPPL-4106

PPPL-4106

## Mechanical Design of the NSTX High-k Scattering Diagnostic

R. Feder, E. Mazzucato, T. Munsat, H. Park,  
D.R. Smith, R. Ellis, G. Labik, and C. Priniski

September 2005

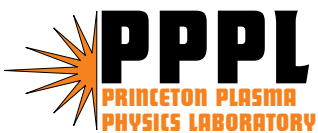

Prepared for the U.S. Department of Energy under Contract DE-AC02-76CH03073.

# PPPL Report Disclaimers

## Full Legal Disclaimer

This report was prepared as an account of work sponsored by an agency of the United States Government. Neither the United States Government nor any agency thereof, nor any of their employees, nor any of their contractors, subcontractors or their employees, makes any warranty, express or implied, or assumes any legal liability or responsibility for the accuracy, completeness, or any third party's use or the results of such use of any information, apparatus, product, or process disclosed, or represents that its use would not infringe privately owned rights. Reference herein to any specific commercial product, process, or service by trade name, trademark, manufacturer, or otherwise, does not necessarily constitute or imply its endorsement, recommendation, or favoring by the United States Government or any agency thereof or its contractors or subcontractors. The views and opinions of authors expressed herein do not necessarily state or reflect those of the United States Government or any agency thereof.

## Trademark Disclaimer

Reference herein to any specific commercial product, process, or service by trade name, trademark, manufacturer, or otherwise, does not necessarily constitute or imply its endorsement, recommendation, or favoring by the United States Government or any agency thereof or its contractors or subcontractors.

# PPPL Report Availability

This report is posted on the U.S. Department of Energy's Princeton Plasma Physics Laboratory Publications and Reports web site in Fiscal Year 2005. The home page for PPPL Reports and Publications is: [http://www.pppl.gov/pub\\_report/](http://www.pppl.gov/pub_report/)

## Office of Scientific and Technical Information (OSTI):

Available electronically at: <http://www.osti.gov/bridge>.

Available for a processing fee to U.S. Department of Energy and its contractors, in paper from:

U.S. Department of Energy  
Office of Scientific and Technical Information  
P.O. Box 62  
Oak Ridge, TN 37831-0062  
Telephone: (865) 576-8401  
Fax: (865) 576-5728  
E-mail: [reports@adonis.osti.gov](mailto:reports@adonis.osti.gov)

## National Technical Information Service (NTIS):

This report is available for sale to the general public from:

U.S. Department of Commerce  
National Technical Information Service  
5285 Port Royal Road  
Springfield, VA 22161  
Telephone: (800) 553-6847  
Fax: (703) 605-6900  
Email: [orders@ntis.fedworld.gov](mailto:orders@ntis.fedworld.gov)  
Online ordering: <http://www.ntis.gov/ordering.htm>

# Mechanical Design of the NSTX High-k Scattering Diagnostic

R. Feder, E. Mazzucato, T. Munsat, H. Park, D.R. Smith, R. Ellis, G. Labik, C. Priniski  
*Princeton Plasma Physics Laboratory  
Princeton, New Jersey*

**Abstract**— *The NSTX High-k Scattering Diagnostic measures small-scale density fluctuations by the heterodyne detection of waves scattered from a millimeter wave probe beam at 280 GHz and  $\lambda=1.07$  mm. To enable this measurement, major alterations were made to the NSTX vacuum vessel and Neutral Beam armor. Close collaboration between the PPPL physics and engineering staff resulted in a flexible system with steerable launch and detection optics that can position the scattering volume either near the magnetic axis ( $\rho \approx .1$ ) or near the edge ( $\rho \approx .8$ ). 150 feet of carefully aligned corrugated waveguide was installed for injection of the probe beam and collection of the scattered signal in to the detection electronics.*

## I. INTRODUCTION

The goal of the mechanical engineering effort for the High-k Scattering diagnostic was to provide for

- An adequate input aperture for probe beam scanning
- A new port and windows for collecting the scattered signal
- Flexible optics for the injection and gathering of the signals
- Support and alignment structures for the optics, corrugated wave guide and detection electronics
- Project management of the installation effort, procurements and vendor contacts

For a description of the physics design and theory refer to [1]. The detection electronics and beam splitting optics were designed through a collaboration with UC-Davis [1].

## II. ALTERATIONS TO THE NSTX VACUUM VESSEL

There were three major alterations to the NSTX vacuum vessel. New port covers at Bay-H and K were fabricated and a large opening in the Neutral Beam armor was created.

### A. Bay-H Port Cover

Figure 1 shows the new Bay-H Port cover. Requirements for the design included providing large ports for the injection of the High-k probe beam, 2 new ports for the FIRETIP diagnostic, support for 3 new neutral beam blocking baffles and ports for cooling tubes and instrumentation. An 8" CF flange with a 6" water free quartz window and gate valve are used for the probe beam entrance.

Port manufacturing was performed by the Hollis Line Machine Company in Nashua, New Hampshire.

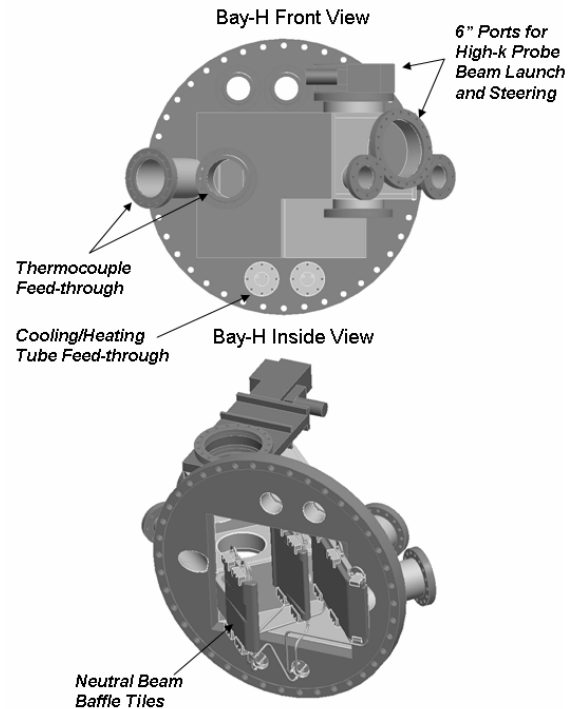

**Figure 1:** The Bay-H port cover provides ports for the High-k Scattering and FIRETIP diagnostic on NSTX. Neutral beam blocking baffles are mounted to the inside of the port.

### B. Neutral Beam Armor and Vessel Modifications

The most challenging engineering came from the opening of the Neutral Beam Armor. Figure 2 shows the aperture that was provided for the scanning High-K probe beam and 2 new FIRETIP channels. Figure 2 also illustrates the mid-plane neutral beam heating that passes through the new opening. To block the neutral beam, 4 new baffle tiles were installed behind the aperture. The baffles are tangent to the diagnostic sight-lines but provide complete vessel protection. Each baffle tile was instrumented to monitor neutral beam heating and tubing runs through the baffle supports for cooling and vacuum bake-out conditioning. ALGOR finite element analysis software was used to predict maximum temperatures on the tiles surface.

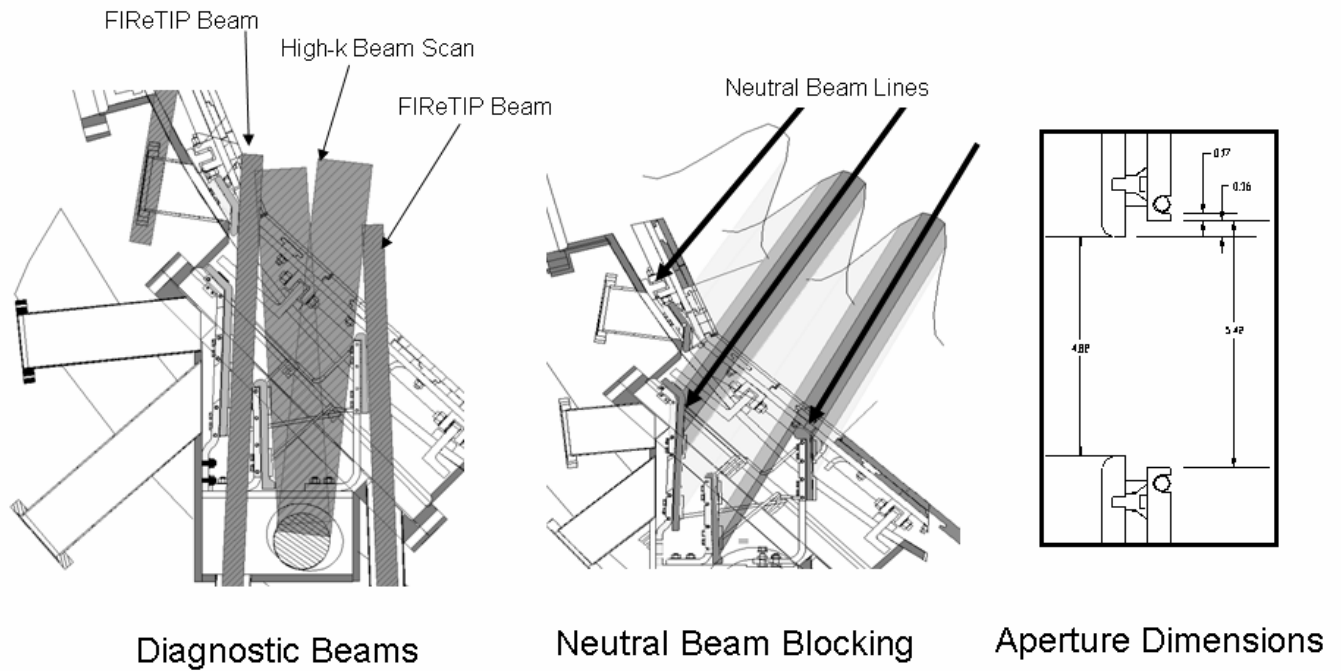

Figure 2: A 5” aperture was cut in to the mid-plane of the Neutral Beam armor. Baffles tiles were arranged behind the new opening to prevent the neutral beam from hitting the vacuum vessel and Bay-H. The baffle tiles are arranged to allow a full range of input angles for the High-k Scattering system.

The baffle tiles are designed to withstand a “worst case” neutral beam fault scenario of 2.8 kW/cm<sup>2</sup> for .75 seconds.

### C. Bay-K Port Cover

Bay-K is a large “neutral beam” style port cover that was in use for the FReTIP, Fast X-Ray diagnostics, NPA and Lithium Pellet Injector. The port cover was removed from NSTX and the lower third was cut open to add the High-k Scattering extension. The port cover was activated when removed and all subsequent machining had to be performed under radiological controls.

Figure 3 is a Pro/Engineer CAD model of the High-k extension for Bay-K. The bathtub shaped weldment was formed and fabricated by the Hollis Line Machine Company. There are ports for supporting the in-vacuum collection mirror bushings and actuators. Five 4 inch diameter water free quartz windows are clamped to a flat-machined vertical face of the extension on Viton o-rings. Small ports along the bottom allow for the future addition of window shutters.

All new port covers for NSTX are leak checked with Helium to 1E-09 Torr l/s, inspected for weld quality under ASME B31.3 and AWS D1.6 and tested for relative magnetic permeability using a Severn gage to a 1.2 reading. 316 Stainless plate was used for Bay-H and Bay-K because the permeability from the mil was found to be more reliable.

### III. STEERING AND COLLECTION OPTICS

17 mirrors were needed to steer and collect the millimeter wave probe beam. The mirrors had to be designed to facilitate alignment while operating in the magnetic field and inside the vacuum vessel.

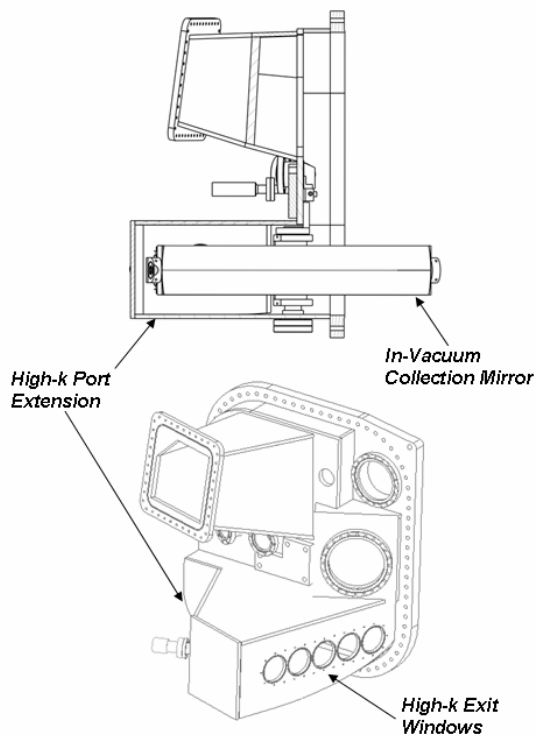
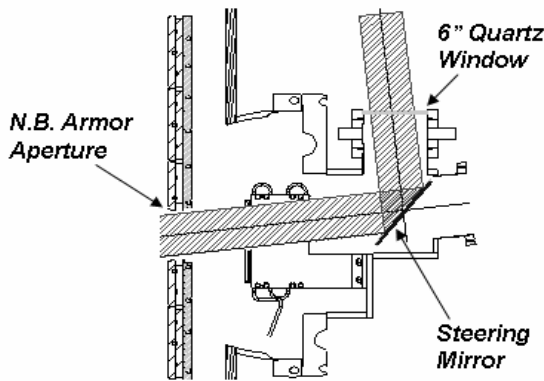

Figure 3: The Bay-K Port Cover Extension houses the 3-meter collection mirror.

### A. In-Vacuum Mirrors

Two in-vacuum 2 degree-of-freedom steerable mirrors were needed to launch and collect the probe beam. Figure 4 is a composite of sections through Bay-H and Bay-K illustrating these mirrors. The launching mirror is assembled as a cartridge on an 8 inch flange that can be plugged in to the Bay-H port cover. It is simultaneously steerable in the toroidal and poloidal directions using two heavy-duty linear vacuum feed-through actuators. Vespel bushings and washers ensure reliable in-vacuum performance. The scattered signals are collected by a large spherical stainless steel mirror inside of Bay-K with a 3 meter radius of curvature. The mirror can be steered toroidally between experiments and adjusted poloidally from inside the vessel.



Elevation Section Through Bay-H

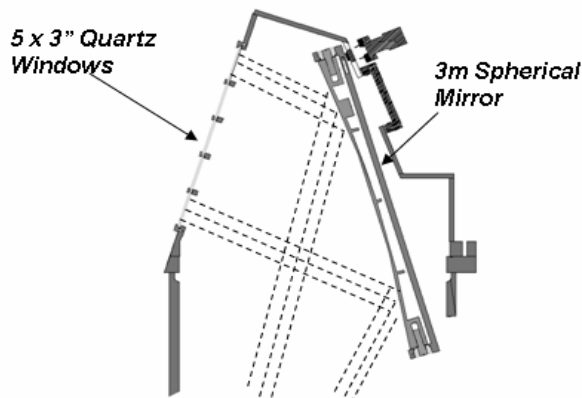

Plan View Section Through Bay-K

Figure 4: In-Vacuum 2 Degree of Freedom steering mirrors were installed inside Bay-H and Bay-K. The Bay-H launching mirror can steer the beam from R=140 cm to R=115 cm in the plasma. Vespel parts are used extensively for in-vacuum motion.

### B. External Mirrors and Optics

The probe beam is focused and steered in to the top of Bay-H by three 6" mirrors mounted on Newport kinematic mounts as shown in Figure 5. The second mirror has spherical curvature for focusing the beam and the third mirror is mounted

on a linear slide. The slide provides a third degree of freedom to the in-vacuum launching mirror. With the external sliding mirror and the internal 2-DOF mirror, the probe beam can be steered from 115 cm major radius to 140 cm at the edge.

Figure 5 also shows the external collection mirror assembly that is hung from the window face of the Bay-K extension. There are 12 flat mirrors that fold the scattered signals in to the corrugated wave guide. Kinematic mounts from Newport and rotation stages from Velmex provide a flexible alignment system.

### C. Beam Mapping and Ray Tracing

The path of the un-scattered beam from outside Bay-H, through the plasma and out through Bay-K was mapped using a FARO measuring arm and laser inside the vessel. Data from the spatial calibration was then used to predict how to set the mirrors to obtain specific scattered beam paths. The calibration data also helped to identify where the un-scattered beam hits the vacuum vessel and other structures. In the future, beam dumps may be placed at these locations to protect the sensitive detection electronics.

Ray-trace simulations of the Gaussian probe beam were used to position the mirrors and to determine the position of the wave-guide entrances to the mirrors. The input mirrors and each collection channel have a specific free-propagation length between the final mirror and the wave guide opening.

## IV. CORRUGATED WAVEGUIDE AND SUPPORTS

150 feet of wave guide was installed in the NSTX test cell. Figure 6 shows how the waveguide was routed around the machine. The .010 and .020 corrugated waveguide and miter bends were salvaged from TFTR experiments.

The probe signal originates from the BWO equipment set up outside the test cell. The waveguide runs through a penetration in the NSTX east wall to Bay-H. A miter-bend beam splitter at Bay-H sends a majority of the signal in to Bay-H with a small percentage split off to the detection electronics below Bay-K for mixing. All of the miter bends along the route have flat mirrors to enable laser alignment. A self-leveling plumb laser was used to align the long runs of corrugated waveguide.

## ACKNOWLEDGMENT

The High-k Scattering installation involved staff from almost every department at PPPL. Personnel in Procurement, Quality Assurance, Health Physics and Accounting provided valuable assistance. The installation would not have been possible without the efforts of PPPL machinists, welders, vacuum technicians and electricians. This project is supported by the U.S. Department of Energy under contract DE-AC02-76-CHO-3073.

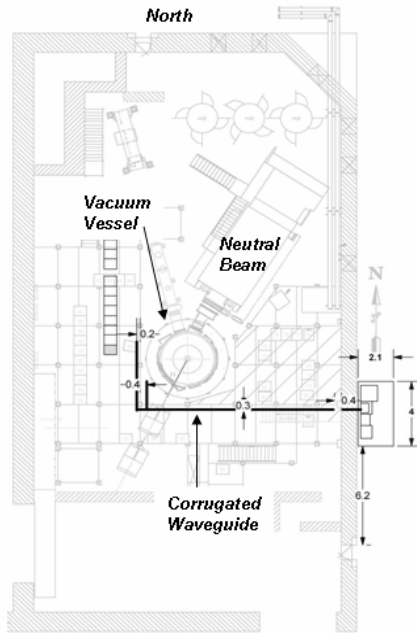

## REFERENCES

- [1] D.R. Smith, E. Mazzucato, H. Park *et al*, "Microwave Scattering System Design for  $\rho_c$  Scale Turbulence Measurements on NSTX," Review of Scientific Instruments, vol. 75, no. 10, pp. 3840-3842, October 2004.

**Figure 6:** Corrugated wave guide was routed from outside the NSTX test cell East wall around to a beam splitter at Bay-H on the South side of the vessel. Another run of wave guide takes the signal from the beam splitter to the detection electronics underneath Bay-K on the West side.

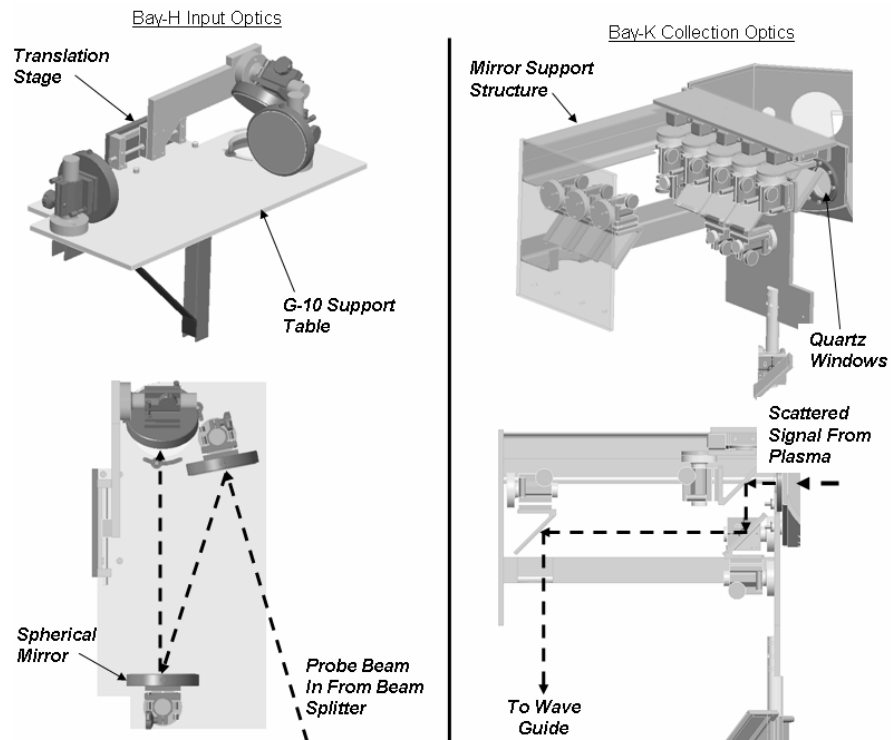

**Figure 5:** External mirrors at Bay-H and Bay-K help to launch and collect the millimeter-wave probe beam signal. On top of Bay-H there are three 6" mirrors that direct the signal in through a 6" quartz window. 12 flat mirrors are mounted off the side of Bay-K to direct the scattered signal out from Bay-K in to corrugated wave guide.

## External Distribution

Plasma Research Laboratory, Australian National University, Australia  
Professor I.R. Jones, Flinders University, Australia  
Professor João Canalle, Instituto de Fisica DEQ/IF - UERJ, Brazil  
Mr. Gerson O. Ludwig, Instituto Nacional de Pesquisas, Brazil  
Dr. P.H. Sakanaka, Instituto Fisica, Brazil  
The Librarian, Culham Science Center, England  
Mrs. S.A. Hutchinson, JET Library, England  
Professor M.N. Bussac, Ecole Polytechnique, France  
Librarian, Max-Planck-Institut für Plasmaphysik, Germany  
Jolan Moldvai, Reports Library, Hungarian Academy of Sciences, Central Research  
Institute for Physics, Hungary  
Dr. P. Kaw, Institute for Plasma Research, India  
Ms. P.J. Pathak, Librarian, Institute for Plasma Research, India  
Dr. Pandji Triadyaksa, Fakultas MIPA Universitas Diponegoro, Indonesia  
Professor Sami Cuperman, Plasma Physics Group, Tel Aviv University, Israel  
Ms. Clelia De Palo, Associazione EURATOM-ENEA, Italy  
Dr. G. Grosso, Istituto di Fisica del Plasma, Italy  
Librarian, Naka Fusion Research Establishment, JAERI, Japan  
Library, Laboratory for Complex Energy Processes, Institute for Advanced Study,  
Kyoto University, Japan  
Research Information Center, National Institute for Fusion Science, Japan  
Professor Toshitaka Idehara, Director, Research Center for Development of Far-Infrared Region,  
Fukui University, Japan  
Dr. O. Mitarai, Kyushu Tokai University, Japan  
Mr. Adefila Olumide, Ilorin, Kwara State, Nigeria  
Dr. Jiangang Li, Institute of Plasma Physics, Chinese Academy of Sciences, People's Republic of China  
Professor Yuping Huo, School of Physical Science and Technology, People's Republic of China  
Library, Academia Sinica, Institute of Plasma Physics, People's Republic of China  
Librarian, Institute of Physics, Chinese Academy of Sciences, People's Republic of China  
Dr. S. Mirnov, TRINITI, Troitsk, Russian Federation, Russia  
Dr. V.S. Strelkov, Kurchatov Institute, Russian Federation, Russia  
Kazi Firoz, UPJS, Kosice, Slovakia  
Professor Peter Lukac, Katedra Fyziky Plazmy MFF UK, Mlynska dolina F-2, Komenskeho Univerzita,  
SK-842 15 Bratislava, Slovakia  
Dr. G.S. Lee, Korea Basic Science Institute, South Korea  
Dr. Rasulkhozha S. Sharafiddinov, Theoretical Physics Division, Institute of Nuclear Physics, Uzbekistan  
Institute for Plasma Research, University of Maryland, USA  
Librarian, Fusion Energy Division, Oak Ridge National Laboratory, USA  
Librarian, Institute of Fusion Studies, University of Texas, USA  
Librarian, Magnetic Fusion Program, Lawrence Livermore National Laboratory, USA  
Library, General Atomics, USA  
Plasma Physics Group, Fusion Energy Research Program, University of California at San Diego, USA  
Plasma Physics Library, Columbia University, USA  
Alkesh Punjabi, Center for Fusion Research and Training, Hampton University, USA  
Dr. W.M. Stacey, Fusion Research Center, Georgia Institute of Technology, USA  
Director, Research Division, OFES, Washington, D.C. 20585-1290

The Princeton Plasma Physics Laboratory is operated  
by Princeton University under contract  
with the U.S. Department of Energy.

Information Services  
Princeton Plasma Physics Laboratory  
P.O. Box 451  
Princeton, NJ 08543

Phone: 609-243-2750  
Fax: 609-243-2751  
e-mail: [pppl\\_info@pppl.gov](mailto:pppl_info@pppl.gov)  
Internet Address: <http://www.pppl.gov>